



**Fire Safety**



**Noise Control**



**Thermal Efficiency**

# ONE HYDE PARK, LONDON, UK

**SIDERISE was the obvious choice for developing a high performance acoustic material with a thickness of less than 35mm in this challenging high profile project.**

## The challenge

This most prestigious London development demanded performance levels that not only met, but exceeded the criteria demanded by Building Regulations 'Approved Document E'. The project required that the final choice in material solution had to be as thin as possible for both practical and ascetic reasons. Independent UKAS accredited laboratory data was required before the product could be finally approved.

## Our solution

SIDERISE FIP high performance acoustic panel was offered, which comprises of four primary layers in composite form, offering a combination of stiffness and damping within a high mass panel with a nominal thickness of only 31mm.

The SIDERISE FIP high performance acoustic panel was tested at Sound Research Laboratories in April 2011 and the test results far exceeded expectations for a thin, single homogenous panel, normally limited to 30-35dB, it achieved 46dB Rw proving that the FIP panel was in a class of its own. It has now been tested for fire properties, achieving EI 60 minutes, making its use as a good fire and acoustic solution in this challenging detail.

This simple effective solution is being considered for use in a large number of projects, for office and residential fit-outs in both the UK and overseas. One Hyde Park was [highly commended by the judges at the 2014 ANC Acoustic Awards](#) due to the complex acoustic challenges faced and the insulation solutions provided.

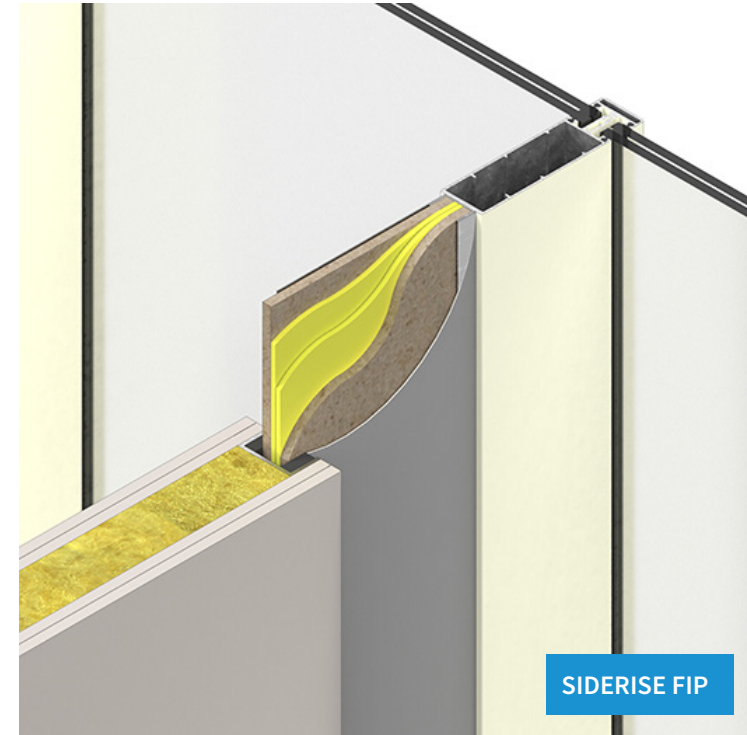

*“We set out to achieve a performance greater than 40dB Rw, a challenge for such a thin, single panel which would normally be limited to around 30-35dB. The result of 46dB Rw for the SIDERISE FIP High Performance Acoustic Panel doesn't quite defy the laws of physics, but it's a very impressive outcome, and a very useful product.”*

Ed Clarke, Clarke Saunders Associates, Noise Consultants.



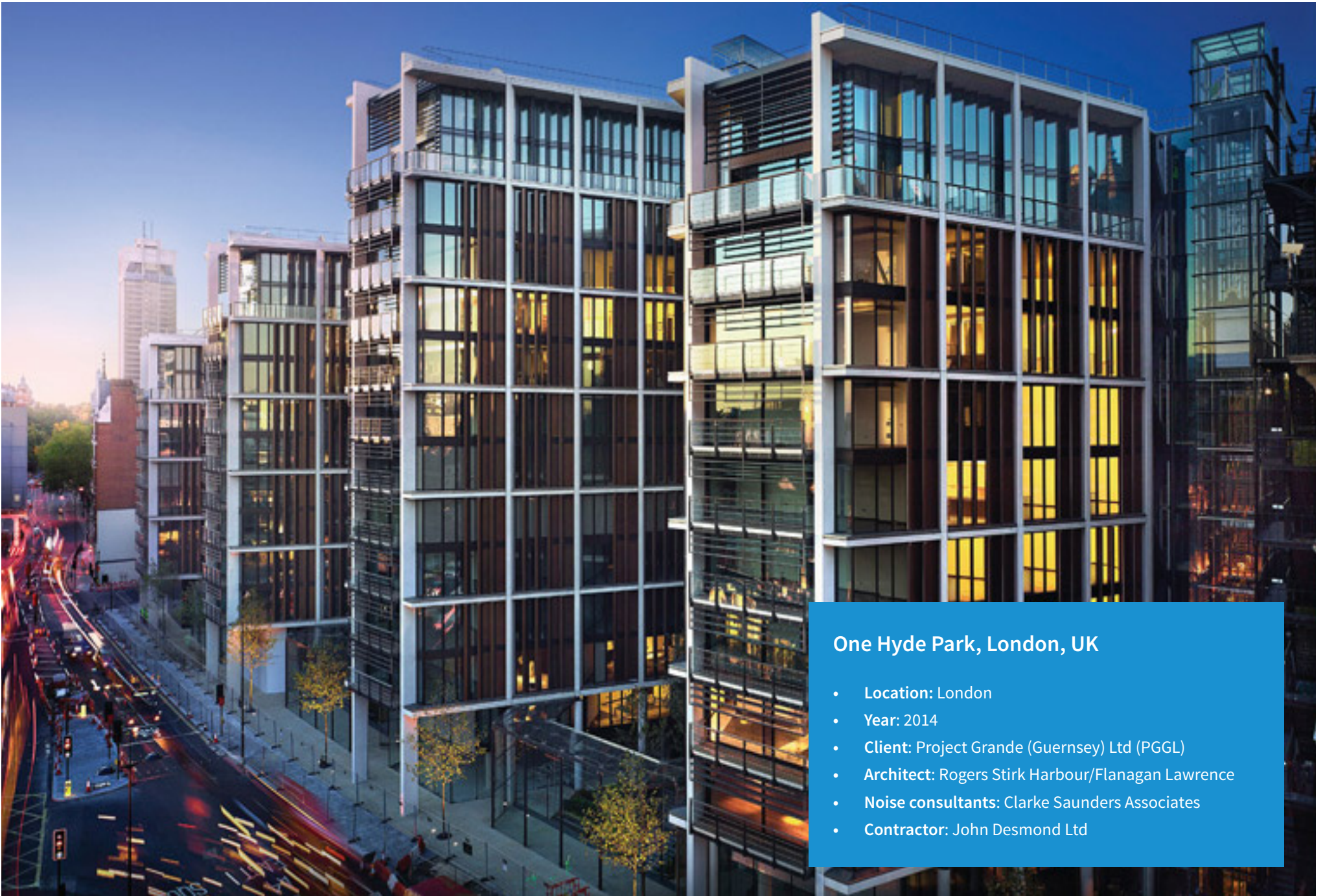

## One Hyde Park, London, UK

- **Location:** London
- **Year:** 2014
- **Client:** Project Grande (Guernsey) Ltd (PGGL)
- **Architect:** Rogers Stirk Harbour/Flanagan Lawrence
- **Noise consultants:** Clarke Saunders Associates
- **Contractor:** John Desmond Ltd





## Olympics 2012 Athletes Village, London, UK

- **Location:** London
- **Year:** 2012
- **Client:** Bovis
- **Architect:** Eric Parry Architects
- **Noise consultants:** Hann Tucker, Sandy Brown Associates, Sharps Redmore
- **Facade Companies:** Techcrete, Thorpe Precast, Decomo
- **Installers:** TECL, Kilnbridge, BDL Group



# OLYMPICS 2012 - ATHLETES VILLAGE, LONDON, UK

**Making London 2012 a success — an acoustic solution that exceeded performance criteria of Pre Completion Testing.**

## The challenge

When the London 2012 design team wanted a third party accredited 'firestop' with 'tested' high acoustic performance to close the movement cavity between the rear of the facade and the partitions and floor slabs, SIDERISE was their only choice.

This most prestigious event in London, the 2012 Olympic Games, demanded performance levels that not only met, but exceeded the criteria demanded by Building Regulations 'Approved Document E'.

The project required that the final choice in material solution had to be a third party accredited firestop, and able to provide proven/tested levels of acoustic performance to achieve the criteria which was set at 5dB above current Building Regulations. Independent UKAS accredited laboratory data was required before the product could be finally approved.

## Our solution

We provided SIDERISE CW-FS curtain wall fire stop system with acoustic upgrades from their acoustic product range.

For the horizontal application CW-FS120, a two hour perimeter barrier firestop was used with a mass barrier overlay of the BM/P5/BOAK/SA and two layers of acoustic composite SIDERISE acoustic void barriers for suspended ceilings - CVB/C10 below.

For the vertical application SR/MF160/BOAK in conjunction with two lines of both SIDERISE linear gap seal and SIDERISE acoustic void closures - AVC/10's.

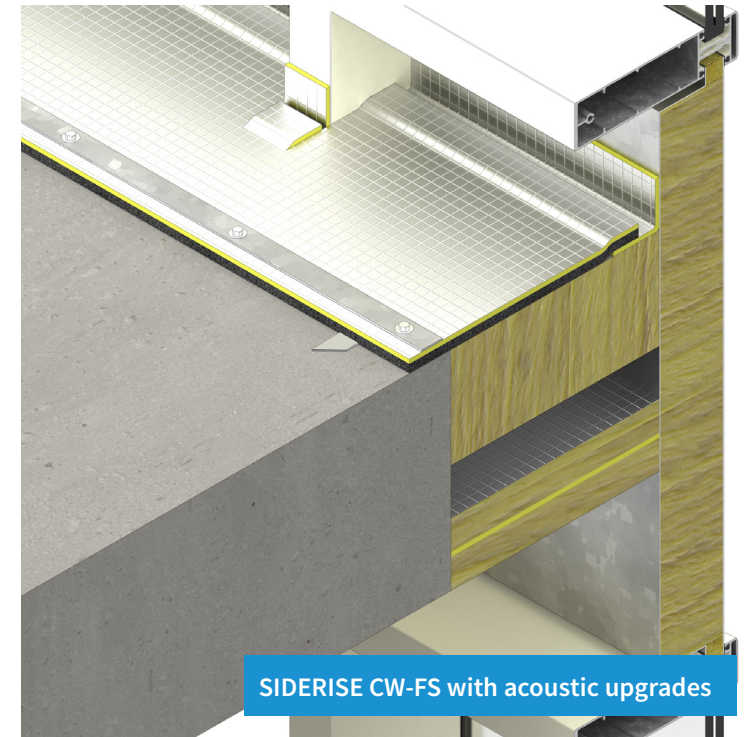

*“Since using these Siderise materials we received no acoustic failure whatsoever.”*

Sharps Redmore, Acoustic Consultants.

facades@siderise.com | 05

# THE SSE HYDRO ARENA, SCOTLAND, UK

Improving the acoustic performance in geometrically complex plenum ceilings with a versatile SIDERISE solution.

## The challenge

An acoustic performance upgrade was required to suit the complex geometry of the arena's bespoke British Gypsum sloping fire rated boarded plenum ceilings. As the ceilings' design offered restricted access, an exclusively boarded solution would prove unsuitable. SIDERISE was approached by Roskel Contracts for its technical expertise in acoustics to find a bespoke solution that would meet the acoustic performance criteria requirements.

## Our solution

SIDERISE used its acoustic barrier/damping mat solution SIDERISE BM/P5/BOAK and BM/P10/BOAK. Overlapping sheets were fitted from below through the structural framework. The SIDERISE Boak sheets were fixed and sealed to provide a continuous membrane which could be shaped and installed to suit the services and structural elements. The result was a fully compliant system.

SIDERISE Boak BM P5 and P10 sheets are thin polymeric sound barriers that provide exceptional flexibility and offer optimum sound reduction and dampening performance. They were originally designed to improve the acoustic insulation performance of metal, wood and plastic being particularly effective at reducing the effect of coincidence dip resonance in these materials.

They are commonly used in construction applications including high performance wall and partition constructions; external cladding to ducts/pipes; component in built up metal roof and cladding systems.

Designed by Foster and Partners as part of the Queen's Dock redevelopment project, the SSE Hydro Arena has proved to be one of Glasgow's most prestigious entertainment venues.

## Awards

- 2013 Scottish Style Awards winner - "Most Stylish Entertainment Venue"
- 2014 AISfpdc Project of the Year Award
- 2014 AISfpdc gold award given to Roskel Contracts in the Judges Award category

*"We came to Siderise on the Hydro Arena as we had concerns that a buildable solution, which met the acoustic performance criteria, could not practically be achieved with an exclusively boarded solution. Having worked with them previously we were confident that they had the range of products and the technical expertise to assist us in developing a practical solution and liaising with both the Architect and Acoustic Consultant. From concept, through mock-ups and the final site installation they provided us with good advice and back up on this extremely complex and challenging project."*

Mike McLaughlin, Managing Direction (Joint), Roskel Contracts



## The SSE Hydro Arena, Scotland, UK

- **Location:** Glasgow
- **Year:** 2013
- **Client:** Scottish Exhibition Centre Ltd. (SECC)
- **Architect:** Foster and Partners
- **Noise consultants:** Sandy Brown associates
- **Contractor:** Lend Lease Construction/Roskel Contracts



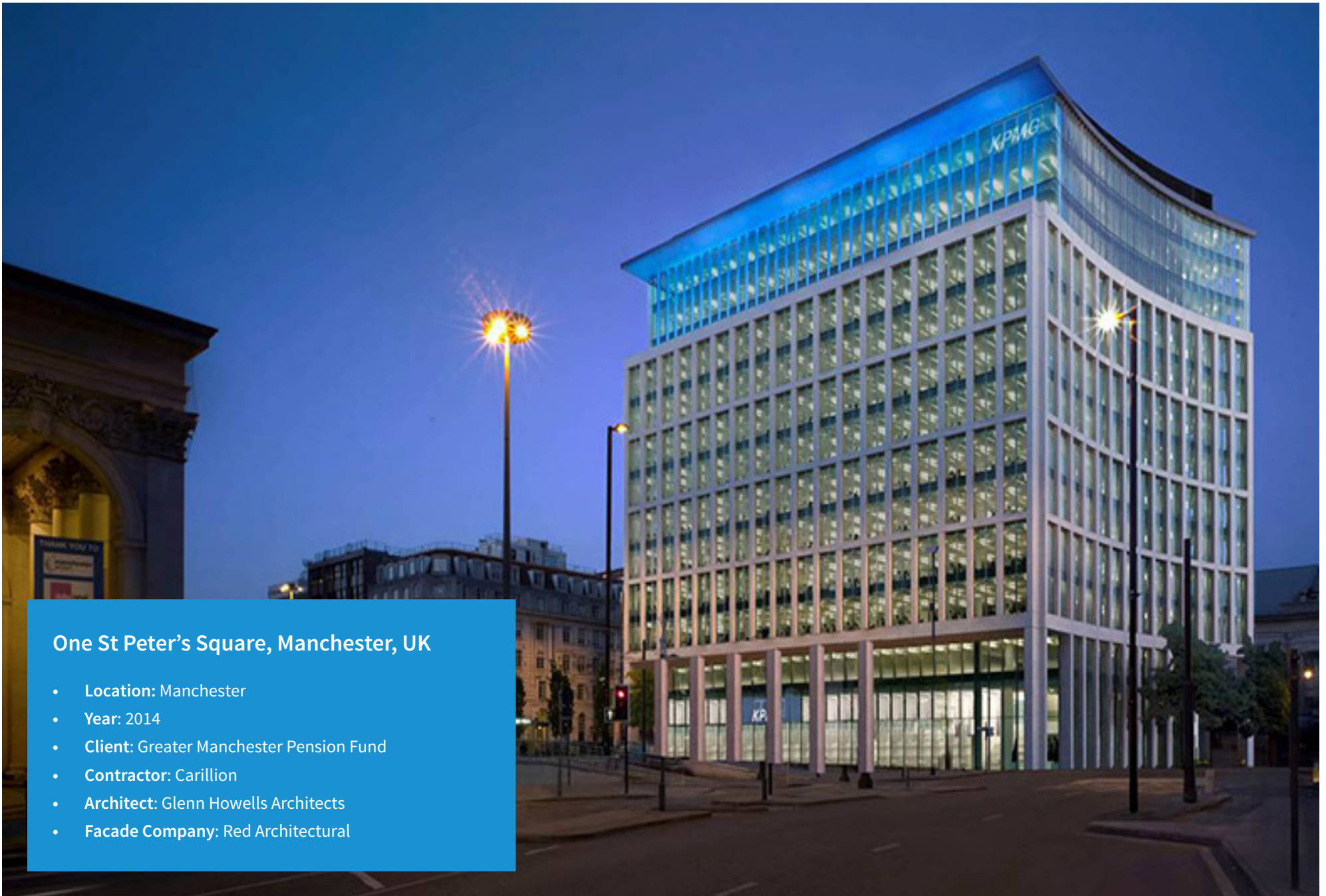

## One St Peter's Square, Manchester, UK

- Location: Manchester
- Year: 2014
- Client: Greater Manchester Pension Fund
- Contractor: Carillion
- Architect: Glenn Howells Architects
- Facade Company: Red Architectural



# ONE ST PETER'S SQUARE, MANCHESTER, UK

Providing 268,000 sq ft of office space in the heart of the Manchester's central business district, the building has been designed to meet the extremely exacting demands of a BREEAM Excellent', Grade A' compliance.

## The challenge

In order to achieve the required acoustic performance both horizontally and vertically, any potential weak points had to be investigated and it has been necessary to upgrade the curtain wall mullions. A hollow mullion is an ideal conduit for flanking sound transmission and even if all other elements, such as the floor slab, partitions or ceilings perform well acoustically, an untreated mullion can drag the overall DnFw performance of the façade below its required specification.

## Our solution

Working with the main contractor, Carillion and Red Architectural who are installing the façade, SIDERISE have been supplying SIDERISE V baffle - MI5 & SIDERISE HB insert - MI6 mullion inserts for the project. These inserts are available for any profile and are cut to the exact internal dimensions of the mullion or transom. The range of inserts have been shown by test to be capable of improving performance by up to 9dB.

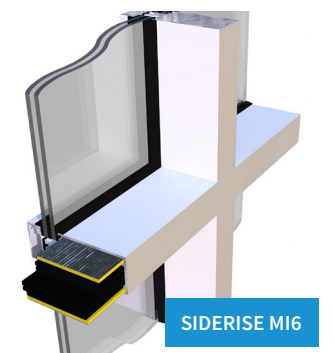
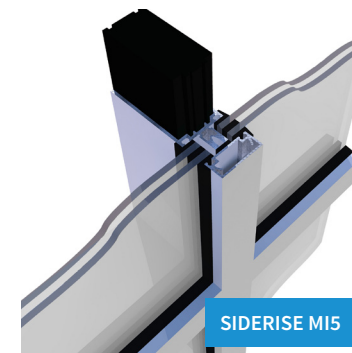
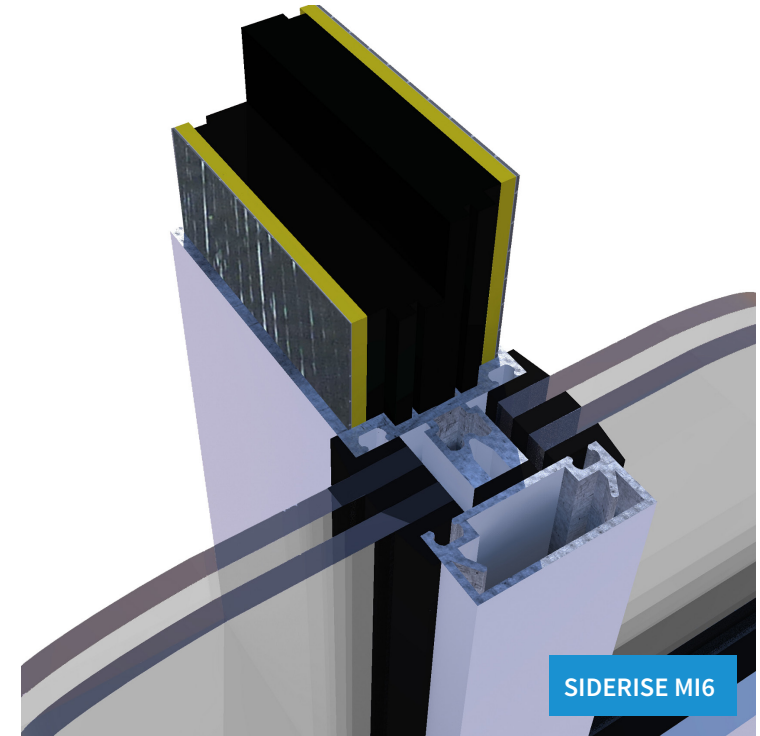



[www.siderise.com](http://www.siderise.com)

