



NEXUS CORE

Fire safe lamella boards for
bonded composite structures

FIRE SAFE STONEWOOL CORE FOR COMPOSITE STRUCTURES SUCH AS ARCHITECTURAL PANELS AND DOORS

- Unique patented manufacturing process creates optimum core performance and cost efficient manufacturing
- Precision engineering leads to easier manufacturing and installation
- The unique open filament net facilitates a strong adhesive bond as well as optimal handleability with larger boards



SIDERISE NEXUS CORE OFFERS BOTH SPECIFIERS AND MANUFACTURERS A FIRESAFE INSULATION CORE WITH SUPERB INTEGRITY, RIGIDITY, FLATNESS AND IN-BUILT STRUCTURAL PERFORMANCE.

Siderise Nexus Core comprises high strength rockfibre lamellae with a uniform vertical fibre structure for optimum mechanical performance.

Our patented lamella technology (refer to p4) offers a dramatic advantage for the production of bonded composite structures that meet all of the performance criteria required for modern industrial and commercial buildings, curtain walling systems, doors and volumetric building elements.

STANDARD SPECIFICATIONS

Various grades of Nexus Core are available to suit differing requirements so please contact the Nexus team at nexus@siderise.com to discuss your requirements.

NEXUS CORE BENEFITS

- Siderise Nexus Core is made from European Fireclass A1 material
- Precision manufacturing and tight tolerances optimise product strength
- Manufacturers can reduce cost/weight with thinner facings
- Low thickness tolerance means that thinner faces remain aesthetically pleasing
- Open filament net facilitates a strong adhesive bond and enables easy handling
- The Nexus process produces a strong, homogeneous stonewool core optimising composite performance

CONTENTS

Product features	3	Fire performance	6
Physical properties	4	Acoustic performance	8
– Composition		Thermal performance	9
– Bonding		Environmental credentials	10
– Dimensions		Service and support	11
Mechanical properties	5		

SIDERISE NEXUS CORE TECHNICAL INFORMATION

Siderise Nexus lamella boards provide a cost effective prefinished rigid core to be used wherever thermal, fire or acoustic insulation is required within a bonded composite structure.

Product Features

Fire safety

Nexus Core is used as a core material for composite structures. In this application it:

- will not contribute to the spread of a fire
- has high temperature resistance, the melting point is more than 1000°C
- does not cause smoke or burning droplets
- releases no aggressive or environmentally unfriendly substances or gases

Water resistance

- Repels water due to water repellent additives.
- Non-hygroscopic and non-capillary – the manufacturing process ensures that no capillary gaps can occur between adjacent strips

Chemical

- Chemically neutral and does not cause or promote corrosion. Resistant to most acids and weak alkaline solutions

Condensation control

- Vapour resistance is negligible and considered to be the same as that for air, helping to avoid condensation
- Moisture condensing from air within the core material is less than 0.02% by volume at 95% humidity

Environmental

- No CFCs or HCFCs are used in the manufacture of the base materials
- Base stonewool material is fully recyclable

Biological

- Vermin and rot proof
- Does not encourage the growth of fungi, mould or bacteria
- Suitable for use (with suitable facings) in hygienic areas

Physical Properties

Composition

Siderise Nexus Core boards are produced using stonewool slab material which has been Euroclass rated A1 and is specifically formulated to a Siderise specification for use in this exacting application.

Stonewool is manufactured from volcanic rock that has been melted in a furnace to temperatures in excess of 1500°C. The molten product is then spun into a wool-like substance which has excellent fire, acoustic and thermal properties.

The unique and patented Nexus process takes this insulating material which is then cut into strips and rotated through 90 degrees so the fibres are perpendicular to the board surface. Additionally the strips are subjected to lateral compression which eliminates any gaps and produces a more homogeneous board with a substantially better rigidity than a standard stonewool slab of the same density. Whilst under compression the product is faced with an open filament net which both maintains the compression and aids handleability.

Bonding

The Core board should be bonded on the net face.

Siderise maintains a close working partnership with major adhesive suppliers to ensure compatibility of materials and the attainment of optimum bond strengths.

For advice regarding manufacturers of appropriate adhesives please contact the Nexus team on nexus@siderise.com.

TABLE 1: Dimensions

		Tolerance
Width	Up to 1200mm in 1mm increments	+/- 2.0mm
Length	Standard boards up to 2400mm in 1mm increments	+/- 2.0mm

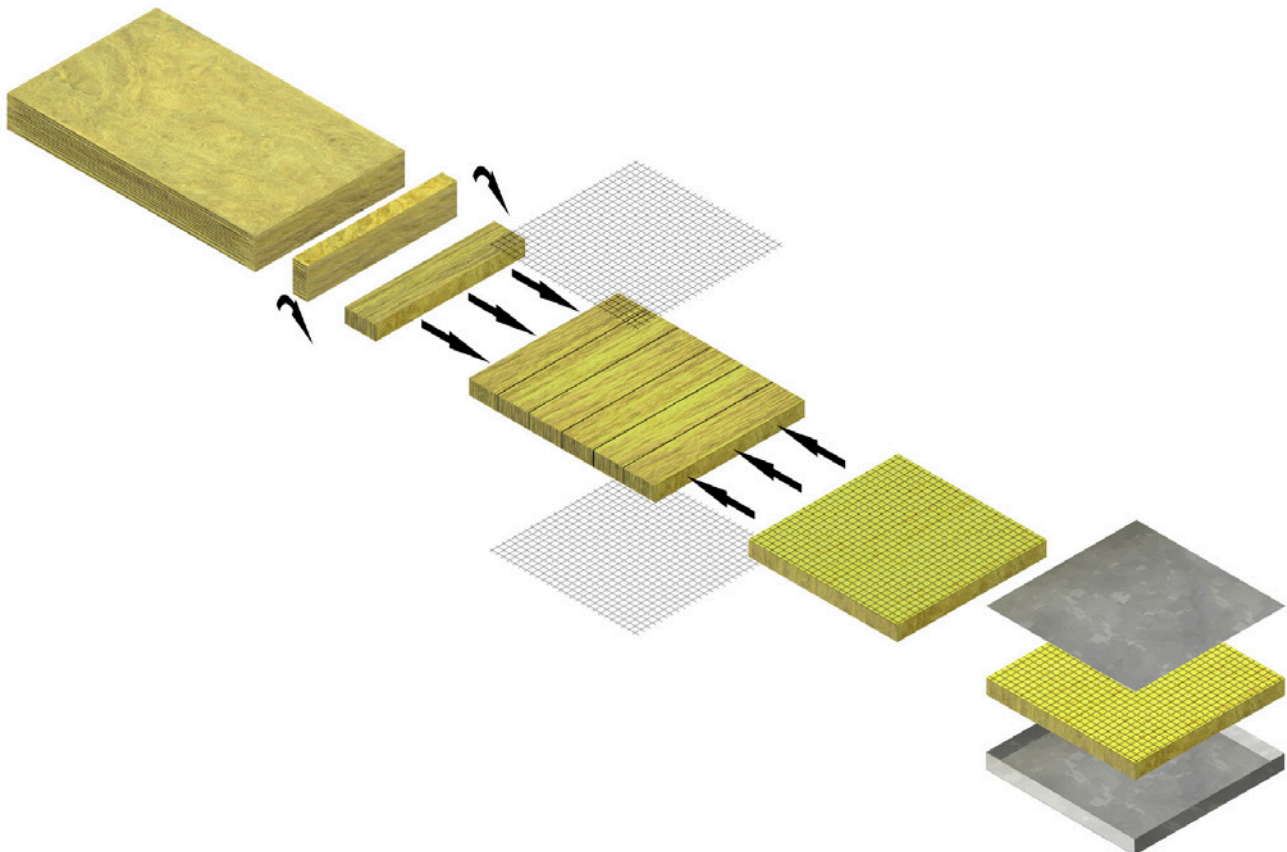

Mechanical Properties

Siderise Nexus Core boards are available in different grades to suit the performance specification required for the composite panel.

The grade of the Siderise Nexus Core board will depend on the individual construction

and/or performance requirements.

Material suitability is dependent upon the intended application of the product and is determined by the relevant trial investigation / testing of the material by the end user. This is typically undertaken

in conjunction with the Siderise Technical Team who are able to provide application and design advice.

For further information contact the Nexus team on nexus@siderise.com

TABLE 2: Mechanical values typical characteristic for standard grades

Effective density	Compression Strength (min)	Tensile Delamination Strength (min)
104kg/m ³	55 kPa	100 kPa
124kg/m ³	75 kPa	150 kPa
164kg/ m ³	130 kPa	190 kPa

Fire classification, testing and performance

EU Fire Classification

The introduction of a single classification system for the Reaction to Fire¹ performance of construction materials across all member states of the EU has made it possible to directly compare different construction materials.

Testing is standardised through the use of BS EN 13501-1: Fire classification of construction products and building materials.

The scope of this standard considers the products only in relation to their end use application which for Nexus Core is as a core for composite structures. It is therefore the fire performance of the finished panel that is considered in relation to Building Regulations. The fine net used is considered a non-substantial element in relation to

British Standards i.e. *BRITISH STANDARD BS EN 13501-1:2007 +A1: 2009 Fire classification of construction products and building elements –Part 1: Classification using data from reaction to fire tests.* states 3.1.6 non-substantial component material that does not constitute a significant part of a non-homogeneous product. A layer with a mass/unit area <1.0 kg/m² and a thickness <1.0 mm is considered to be a non-substantial component.

NOTE Two or more non-substantial layers that are adjacent to each other (i.e. with no substantial component(s) in between the layers) are regarded as one non-substantial component when they collectively comply with the requirements for a layer being a non-substantial component.

For construction products such as composite panels products there are seven possible Reaction to Fire levels – A1, A2, B, C, D, E and F. Additionally the material's tendency to produce smoke and flaming droplets/particles is rated. The level of smoke release has three possible levels: s1, s2 and s3 with s3 being the worst. The level of burning droplets /particles also has three possible levels: d0, d1 and d2 with d2 being the worst.

Fire Resistance¹ of Panel Systems

The fire rating of a panel system will depend on a variety of factors including:

- Nexus Core grade and thickness
- Facing type and thickness
- Panel cover width, span, joint detail and fixings

To properly determine fire resistance of a system a fire test is necessary.

¹ **Reaction to Fire** is the measurement of how a material will contribute to the fire development and spread. This is different to **Fire Resistance** where a system is tested to see how well it resists fire breaking through due to flames, combustible gasses or elevated temperature on the reverse of the system

Fire

Fire resistance testing of panel systems can either be at an intermediate or large scale. Over the last 25 years many panel systems incorporating Nexus cores have been independently tested.

Intermediate scale testing

A composite panel, of the following construction, was tested at Exova in May 2018 using the principles of EN 1366 part 4 and EN 1363 part 1.

- Inner and Outer faces: 1.5mm powder coated aluminium
- Insulating core : Nexus Core 100mm thick with nominal density 104kg/m³

Result was an insulation pass at 90 minutes and an integrity pass of two hours with no issues on either.

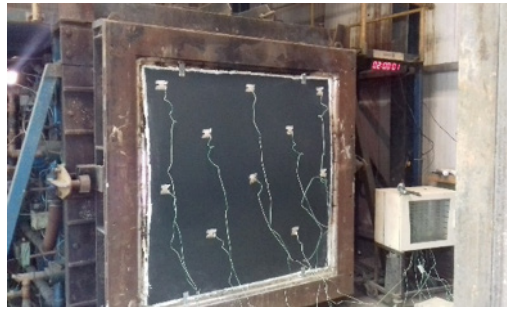

▲ Test rig at two hours testing

- ▶ Back of test sample after 2 hours testing showing the furnace exposed face of the Nexus Core insulation



As a guide to performance, Table 3 shows the performance of a typical glazing infill panel tested to BS 476: part 22 :1887. The panel construction was as follows:

- **Outer skin:** 2mm polyester powder coated aluminium
- **Core:** Nexus Core with nominal density 124kg/m³ plus high density edging strips
- **Inner skin:** 1mm galvanised tray

TABLE 3 : Fire performance for typical glazing panel comprising Siderise Nexus Core board

Effective density	Thickness (mm)	U Value	Fire rating	
			Integrity (E)	Insulation (I)
124kg/m ³	86	0.51 W/m ² .K	30	30
124kg/m ³	112	0.39 W/m ² .K	60	60
124kg/m ³	135	0.33 W/m ² .K	60	60*
124kg/m ³	160	0.27 W/m ² .K	60	60*

* Although these panels have a minimum rating of 60/60, increased ratings are achievable dependent on the curtain walling system used. This would require independent assessment.

Large scale testing

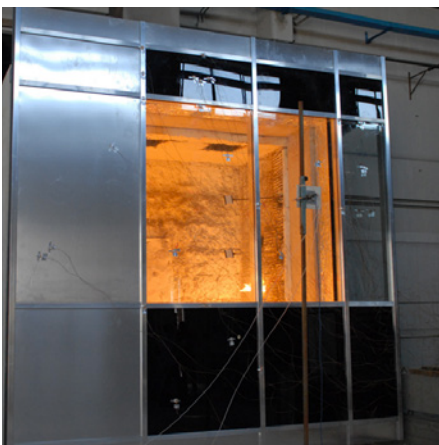

As a guide to performance a full curtain wall assembly was tested to BS EN 1364-3:2006 fire resistance test for non-load bearing elements achieving a performance of REI 30 with no issues regarding integrity or insulation. The assembly consisted of the following:

- Fire rated façade system to suit specific fire rating
- Siderise Passive Fire Protection seals to all juncture with furnace
- Standard 'Pyro glass' 28mm IGU's

- Non-fire rated 6mm toughened glass ceramic spandrels protected with Nexus Fusion boards at nominal density of 77kg/m³ and 146mm thickness
- Bonded composite panel with 28mm rebate and the following construction:
 - **Outer skin:** 2mm polyester powder coated aluminium
 - **Core:** Nexus Core with nominal density 124kg/m³
 - **Inner skin:** 0.9mm galvanised tray

Siderise Nexus Core boards offer exceptional acoustic performance.

As with fire performance the acoustic performance is system specific and is heavily influenced both by the materials used and the way they are put together.

Siderise Nexus Cores have been used in many different systems over the past two decades. Siderise acoustic experts are on hand to help clients to offer advice which can help manufacturers to design the optimal performance

The indicative diagram to the right shows the result of a system which has been laboratory tested which is the only accurate method for ascertaining the R_w value of a system. The table below gives estimated acoustic values for a range of composite systems which have been estimated with use of 'Predictive Software'

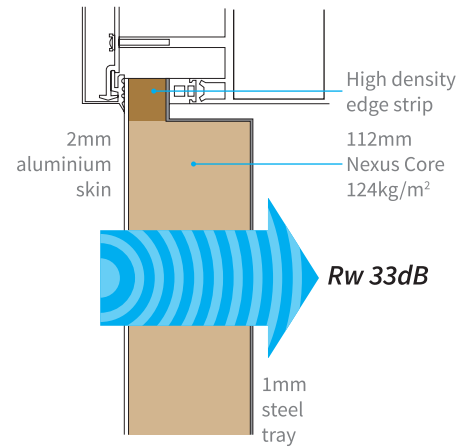

TABLE 4 : Acoustic performance for composite panels with Siderise Nexus Core*

Outer Face S = Steel A = Aluminium	Inner Face S = Steel A = Aluminium	Nexus Core density (kg/m ³)	Nexus Core thickness (mm)	R _w * (dB)	R _w + C _{tr} * (dB)
2.0mm (A)	0.7mm (S)	104	30mm	34dB	27dB
2.0mm (A)	2.0mm (A)	104	30mm	34dB	27dB
1.2mm (S)	1.2mm (S)	104	30mm	40dB	31dB
1.5mm (A)	1.5mm (A)	124	50mm	33dB	26dB
1.5mm (A)	0.9mm (S)	124	50mm	36dB	28dB
0.9mm (S)	0.9mm (S)	124	50mm	39dB	30dB
0.7mm (S)	0.9mm (S)	124	100mm	43dB	29dB
1.5mm (A)	0.9mm (S)	124	100mm	41dB	29dB
1.5mm (A)	1.5mm (A)	124	100mm	37dB	27dB

* These values are estimated by our acoustic experts using 'Predictive Software'. These values should be discussed with the project noise consultant for confirmation/acceptance

Thermal performance

Siderise Nexus Core boards exhibit thermal conductivity's between 0.041W/mK and 0.048W/mK.

For a given construction, the thermal resistance is determined by a combination of the grade of material and its thickness.

Siderise Nexus Core does not age and the heat transmission coefficient remains constant providing permanently durable properties.

As the material does not shrink or warp, thermal bridges cannot be formed between the insulating boards.

Please contact the Siderise Technical Sales Team for advice regarding the thermal characteristics of the bonded panel in conjunction with all interfacing and surrounding elements.

Nominal density

Thermal Conductivity λ_{10} (90/90 Lambda for 100 sample)

104kg/m ³	0.041 W/mK
124kg/m ³	0.044 W/mK
164kg/m ³	0.048 W/mK

Environmental

Siderise is committed to the use of innovative materials and the development of products and technologies for a more sustainable future. We consider the environment in everything we do from the purchasing of our raw materials, the manufacturing processes we use to produce our products through to their final end use.

Nexus Core production

The Nexus technology delivers multiple sustainable benefits which include :

- Automated system optimises the mechanical properties of the end product which minimises waste and raw material usage
- Single process can be used for a wide range of products used in multiple sectors
- Fire products are made in one piece enabling fast, simple and economical installation
- The unmatched movement characteristics of the Nexus products increases their service life and maintains fire integrity

In addition Siderise Nexus Core has the following features

- It contains no Volatile Organic Compounds (VOC's) and no very Volatile Organic Compounds (vVOC's)
- Zero ozone depleting potential
- Zero global warming potential
- Stonewool material is infinitely recyclable

Service and Support

- Specification advice – including fire, acoustic and thermal performance
- Full technical support
- Bespoke manufacturing and kit supply service to close tolerances
- Built-in independently-qualified fire performance
- Advice and training on best way to handle and use our products

SALES AND TECHNICAL SUPPORT

T: +44 (0) 1656 730833

E: nexus@siderise.com

